

Front view

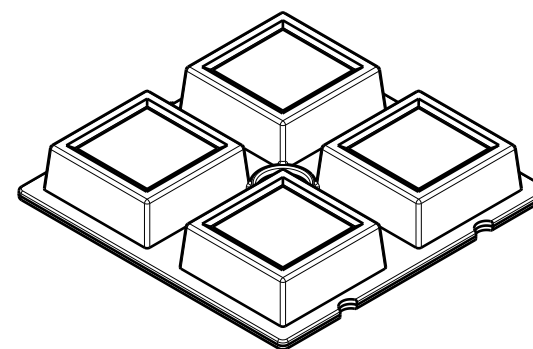

Isometric view  
Scale: 1:1

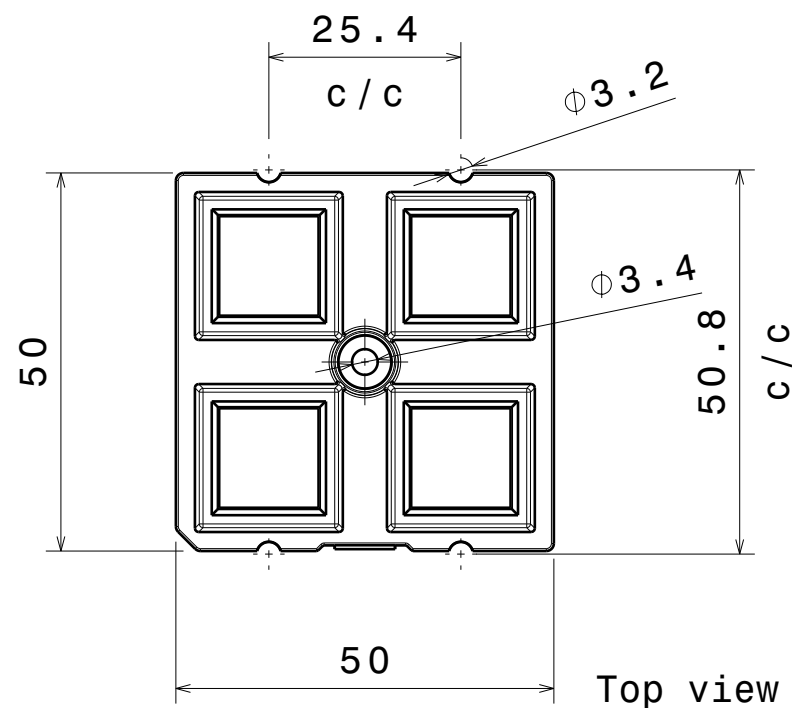

Top view

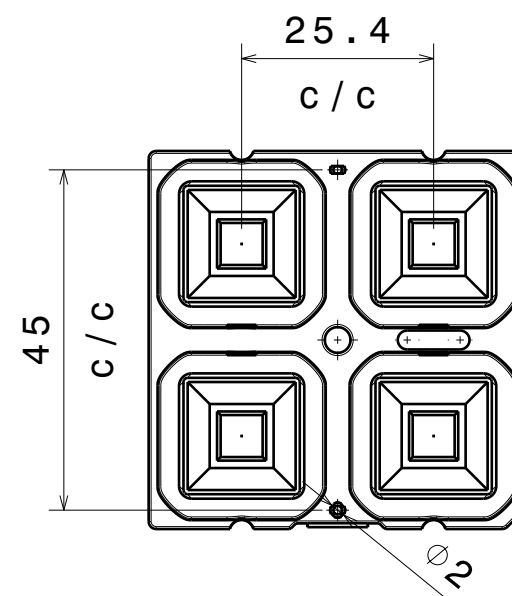

Bottom view

PART	TYPE	MATERIAL	COLOR / COATING
C12361_HB-2X2-W		PMMA	

**MECHANICAL DRAWING**

PRODUCT  
**HIGHBAY**

**LEDiL<sup>®</sup>**

Plastic moulding general tolerances according to DIN 16901-130 and applies if not otherwise shown in the drawing.  
Silicone moulding general tolerances according to ISO 3302-1 Class M3 and applies if not otherwise shown in the drawing.

FIRST ANGLE PROJECTION:

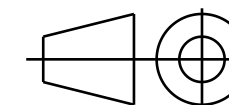

This drawing is the property of LEDiL Oy. It may not be copied or otherwise distributed without prior written permission from LEDiL Oy.

SCALE 1:1

WEIGHT 10,4 g

A3 SHEET 1/1